

AZ695

SENSITIVE SUBMINIATURE RELAY

FEATURES

- Extremely small footprint
- Thin vertical profile
- 1 Form A contact up to 5 Amp switching capability
- High sensitivity, 100 mW pickup
- Dielectric strength 3000 Vrms contact to coil
- Epoxy sealed
- UL file E44211
- CSA file 74461

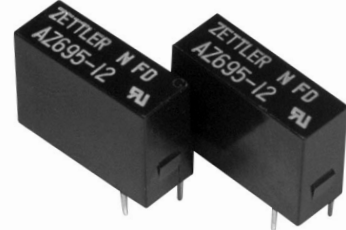

CONTACTS

| | |
|--------------------|--|
| Arrangement | SPST (1 Form A) |
| Ratings | Resistive load: Max. switched power: 150 W or 1250 VA Max. switched current: 5 A Max. switched voltage: 150 VDC* or 250 VAC Inductive load (p.f. = 0.40, L/R = 7 ms) 2 A at 250 VAC, 30 VDC |
| UL, CSA | 5 A at 30 VDC resistive 5 A at 250 VAC general use 1/10 HP 120 VAC * Note: If switching voltage is greater than 30 VDC, special precautions must be taken. Please contact the factory. |
| Material | Options: Silver cadmium oxide Silver cadmium oxide with gold plating |
| Resistance | < 30 milliohms initially |

COIL

| | |
|------------------------------------|-------------------------------------|
| Power | |
| At Pickup Voltage (typical) | 100 mW |
| Max. Continuous Dissipation | 550 mW at 20°C (68°F) ambient |
| Temperature Rise | 25°C (45°F) at nominal coil voltage |
| Temperature | Max. 105°C (221°F) |

NOTES

| |
|---|
| 1. All values at 20°C (68°F). |
| 2. Relay may pull in with less than "Must Operate" value. |
| 3. Minimum permissible contact load: AgCdO contact: 100 mA at 5 VDC AgCdO contact with gold plating: 10 mA at 5 VDC |
| 4. Specifications subject to change without notice. |

GENERAL DATA

| | |
|--|--|
| Life Expectancy Mechanical Electrical | Minimum operations 2 X 10 ⁷ operations 1 X 10 ⁵ at 5 A, 30 VDC or 250 VAC Res. |
| Operate Time (typical) | 6 ms at nominal coil voltage |
| Release Time (typical) | 3 ms at nominal coil voltage (with no coil suppression) |
| Dielectric Strength (at sea level for 1 min.) | 750 Vrms between open contacts 3000 Vrms contact to coil |
| Insulation Resistance | 100 megohms min. at 20°C, 500 VDC, 50% RH |
| Dropout | Greater than 10% of nominal coil voltage |
| Ambient Temperature Operating Storage | At nominal coil voltage -40°C (-40°F) to 70°C (158°F) -40°C (-40°F) to 105°C (221°F) |
| Vibration | 0.062" (1.5 mm) DA at 10–55 Hz |
| Shock | 10 g |
| Enclosure | P.B.T. polyester |
| Terminals | Tinned copper alloy, P.C. |
| Max. Solder Temp. | 270°C (518°F) |
| Max. Solder Time | 5 seconds |
| Max. Solvent Temp. | 80°C (176°F) |
| Max. Immersion Time | 30 seconds |
| Weight | 3 grams |
| Packing unit in pcs | 25 per plastic tube / 1000 per carton box |

ZETTLER electronics GmbH

Junkersstrasse 3, D-82178 Puchheim, Germany

Tel. +49 89 800 97 0
Fax +49 89 800 97 200

office@ZETTLERelectronics.com
www.ZETTLERelectronics.com

AZ695

RELAY ORDERING DATA

| COIL SPECIFICATIONS | | | | ORDER NUMBER | |
|---------------------|------------------|---------------------|--------------------------------|---------------|---------------------------------|
| Nominal Coil VDC | Must Operate VDC | Max. Continuous VDC | Coil Resistance Ohm $\pm 10\%$ | AgCdO Contact | AgCdO with Gold Plating Contact |
| 5 | 3.5 | 8.4 | 125 | AZ695-5 | AZ695-5G |
| 6 | 4.2 | 10.1 | 180 | AZ695-6 | AZ695-6G |
| 9 | 6.3 | 15.2 | 405 | AZ695-9 | AZ695-9G |
| 12 | 8.4 | 20.2 | 720 | AZ695-12 | AZ695-12G |
| 18 | 12.6 | 29.5 | 1,620 | AZ695-18 | AZ695-18G |
| 24 | 16.8 | 40.5 | 2,880 | AZ695-24 | AZ695-24G |

MECHANICAL DATA

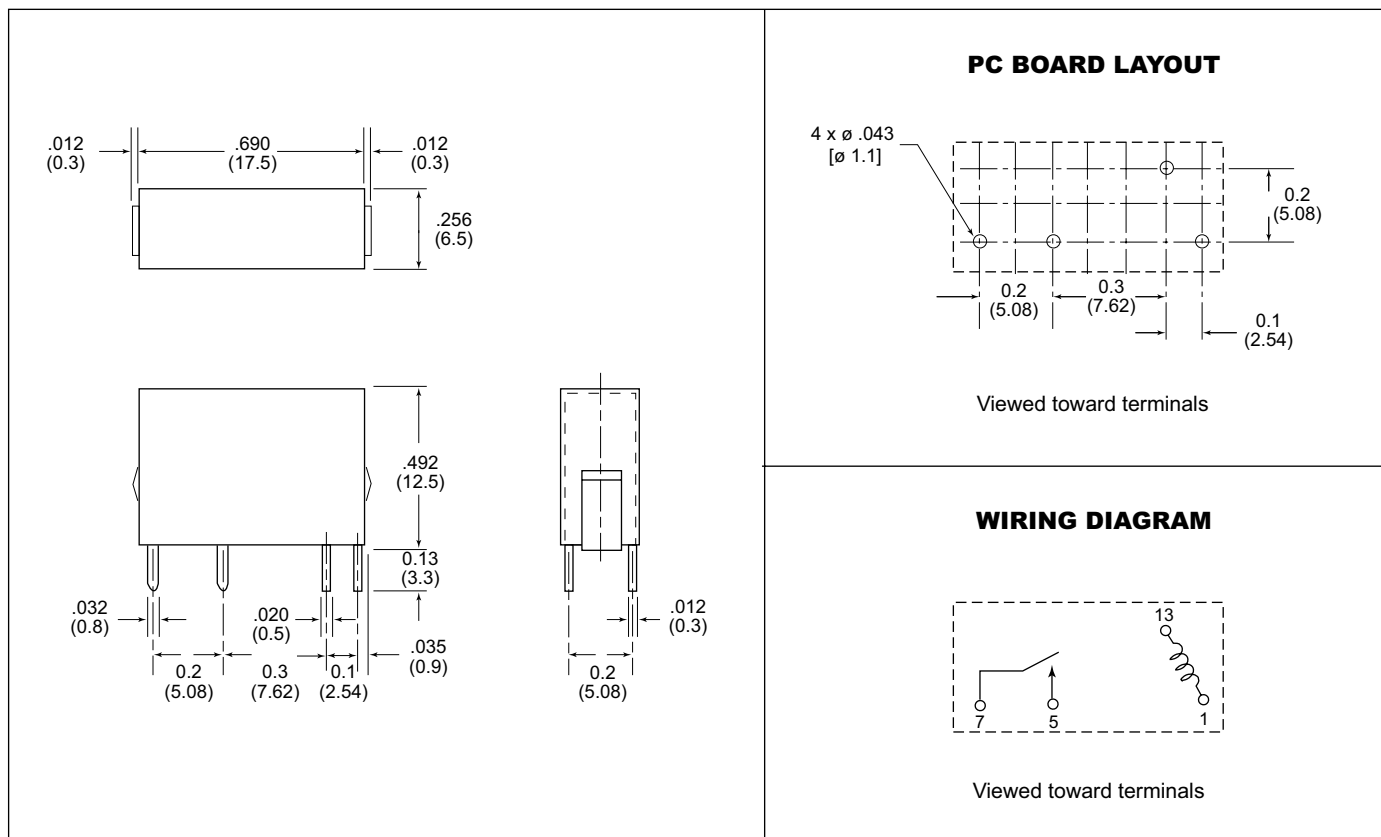

Dimensions in inches with metric equivalents in parentheses. Tolerance: $\pm .010$ "

ZETTLER electronics GmbH

Junkersstrasse 3, D-82178 Puchheim, Germany

Tel. +49 89 800 97 0

Fax +49 89 800 97 200

office@ZETTLERelectronics.com

www.ZETTLERelectronics.com

2004-08-12